

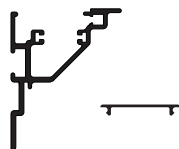

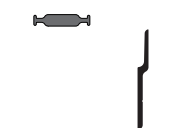

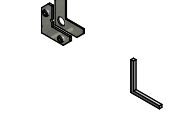

PRODUCT UPDATE: 2" Soft Signage Tensioning System

Ideal for all dye-sublimation and direct printed fabrics.

	Part	Part Number	Length	Finish
	2" Soft Signage Tension Frame	3090	24'-5"	Mill
	2" Soft Signage Plastic Cover	3093	12'-2"	Black
	Soft Signage Grip Strip II	3097	12'-2"	Black
	Soft Signage Tension Frame Z-Clip	3099	12'-0"	Mill
	2 Piece Corner Key	5890		
	Corner Angle (2" x 2" x 3/16")	5303	3/16"	Mill
	Bundled- Frame, Cover, and Grip Strip	B3090	12'-2"	

Features & Benefits

- Fast, easy frame assembly.
- No sewing or silicone beads required.
- Easy snap on and off cover.
- No painting required.
- Light weight frame - single and double face.
- Full bleed face.
- Fabric does not need to be cut to exact size.
- Designed for illuminated and non-illuminated applications.

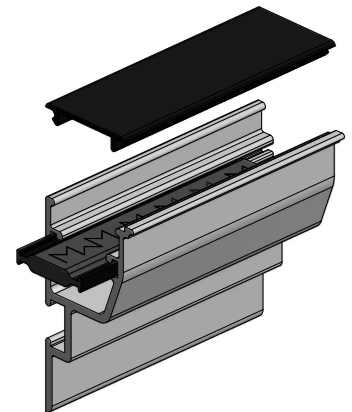

Pre-Cut Kits Available

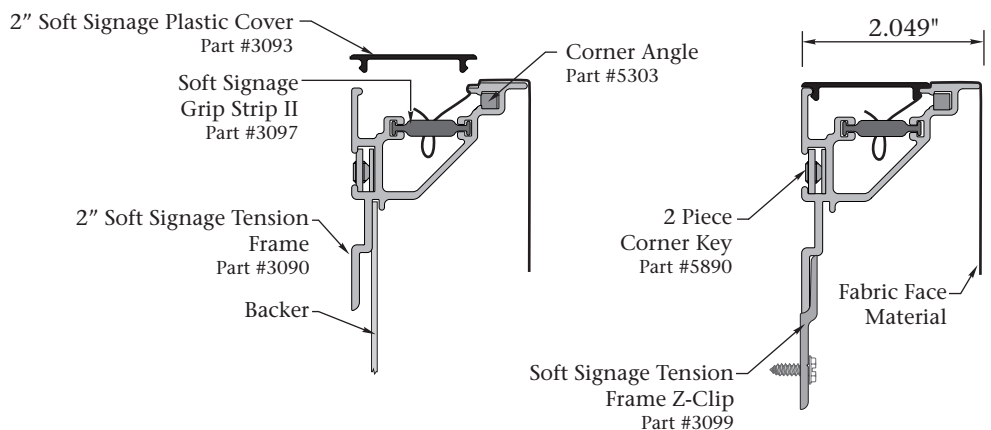
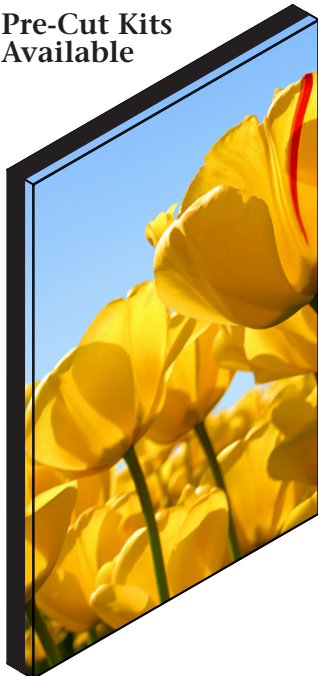

US Patent Number 8,595,966
Canadian Patent Number 2,754,507